

NOTES:

1. THRUST BLOCKS TO BE USED ONLY WHERE SPECIFICALLY IDENTIFIED.
2. ALL BURIED VALVES SHALL HAVE A CAST IRON VALVE BOX AND COVER.
3. CONCRETE SHALL BE 2,500 PSI MINIMUM.
4. CONTRACTOR TO MODIFY BEARING REQUIREMENTS FOR HIGHER WORKING PRESSURES, AND ALLOWABLE SOIL BEARING PRESSURE.
5. WRAP ALL FITTINGS WITH 6 MIL PLASTIC SHEETING BEFORE POURING THRUST BLOCK

MINIMUM SQUARE FEET OF THRUST AREA*					
PIPE SIZE (INCHES)	TEE OR PLUG	90° BEND	45° BEND	22.5°, 11.25° BENDS OR REDUCER	VALVES
3	0.80	1.10	0.60	0.30	0.80
4	1.40	2.00	1.10	0.60	1.40
6	3.20	4.50	2.40	1.20	3.20
8	5.70	8.00	4.30	2.20	5.70
10	8.80	12.50	6.80	3.40	8.80
12	12.70	18.00	9.70	5.00	12.70
14	17.30	24.50	13.30	6.80	17.30
16	22.59	32	17.30	8.80	22.60
18	28.59	40.50	21.90	11.20	28.60
20	35.41	50.00	27.00	13.80	34.90
24	50.90	71.97	39.00	19.86	50.30

* SOIL BEARING PRESSURE= 2000 PSF
 WORKING PRESSURE RATING= 150 P.S.I.
 SAFETY FACTOR= 1.5

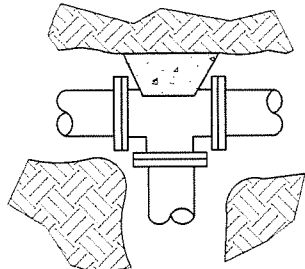

TEE

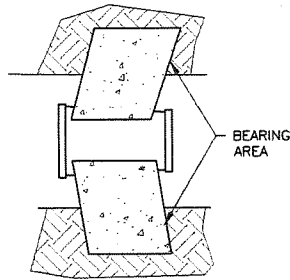

REDUCER

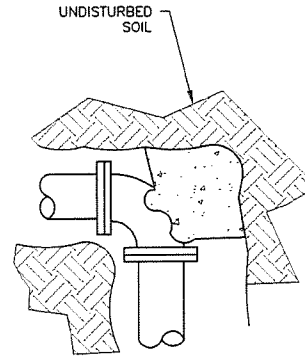

BEND

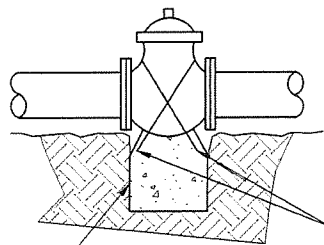

VALVE

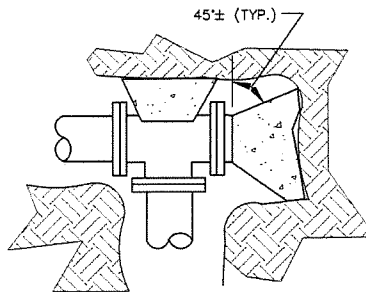

TEE (PLUGGED)

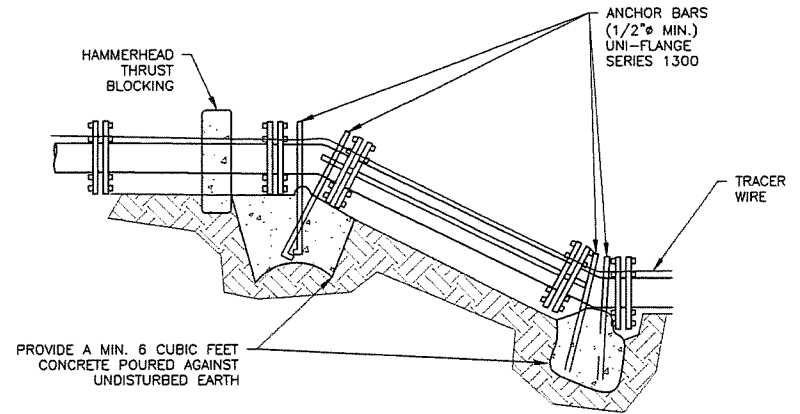

VERTICAL BEND DETAIL

REVISIONS	
DATE	DESCRIPTION

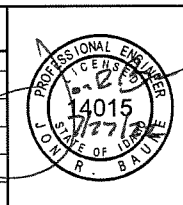

HAYDEN LAKE IRRIGATION DISTRICT

THRUST BLOCK DETAIL

HLID DETAIL #: **012**

SCALE: NONE DATE: July, 2022

DWG: 012 - THRUSTBLOCK(11-2020).dwg APPROVED: BR